



ELECTROCOMPANIET

If music really matters...



EMC 1UP

Reference CD Player

Owner's Manual

ENG

Unpacking the EMC 1UP

Immediately upon receipt of the EMC 1UP CD player, inspect the carton for possible damage during shipment. The carton and packaging have been designed to provide the safest possible protection for transport of your EMC 1UP. Unpack the unit carefully. Save all packaging materials for future shipment.

The contents of the carton

- 1 pcs Electrocompaniet: EMC 1UP CD player.
- 1 pcs AC main cord.
- 1 pcs inspection card.
- 1 pcs CD clamp.
- 1 pcs self-adhesive felt ring for placement of the CD clamp when not in use.
- 2 pcs Allen keys for securing of the Electro Mechanical Cancellation System.
- 1 pcs remote control
- 2 pcs batteries.

Important Notice

The transport screw must be removed for proper operation. When moving the CD player. Always re-insert and tighten the transport screw to avoid severe damage to the unit!

For optimal sonic performance, the EMC 1UP should be burned in for a minimum time of 72 hours. The easiest way to burn in your EMC 1UP is to put a disc in REPEAT mode with the rest of your system turned off. In daily operation, switch off the CD player by using the STANDBY button on the remote. If the CD player has been switched off, allow two hours of warm-up to optimize sonic performance. Due to high class A operation in all Electrocompaniet designs, it is normal for the CD player to feel warm. Proper ventilation is important. The CD player should by no means be completely covered. A good rule of thumb is to allow at least 3 - 5 cm (1 - 2 inches) of air sidewise, and 5 - 8 cm (2 - 3 inches) above the CD player. Please refer to Owner's Manual for removal of the CD transport screw.

Set up procedure

How to remove and UN secure transport necessities.

1. Remove the two wing bolts and the wing nut located underneath the unit.

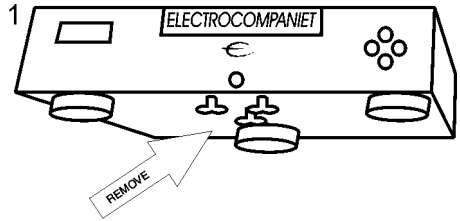

2. Unscrew the Allen screws holding the gold sign marked «Mechanical Cancellation System» with the smallest Allen key and remove the bracket.

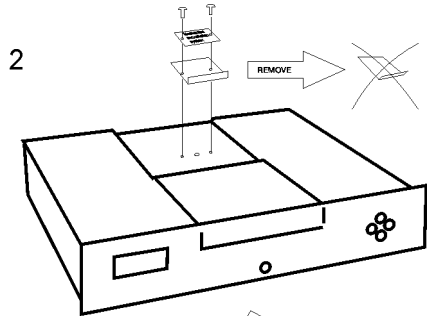

3. To loosen the transport screw located underneath the golden sign, use the largest Allen key and unscrew counter clockwise for about 10 turns. Do not remove this allen screw.

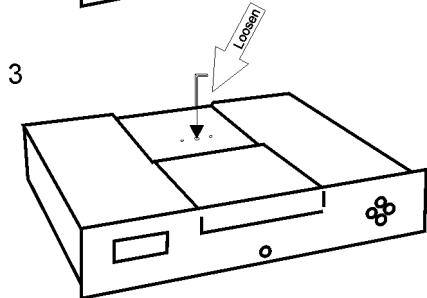

4. Put the gold sign back and fasten it with the Allen screws.

! Important!

Keep Allen keys and all transport necessities in a safe place for future use. Always tighten the transport screw on top first, then the wing nut and wing bolts when moving the CD Player. The cancellation system weights close to six kilograms alone. If not securely fastened, the CD player will be severely damaged, resulting in void of warranty. Do not over-tighten the transport screw.

Mains

Before connecting to Mains check that the mains voltage printed on the rear panel of the CD Player corresponds to the line voltage in the territory were you intend to use the unit.

How to avoid damages

A good operating practice is to turn off all equipment before any connections or disconnections are made. Do not under any circumstances connect or disconnect equipment when power is turned on. The design of the RCA plug generates a huge transient when inserted. Connecting or disconnecting equipment with the power on could severely damage both speakers and amplifier(s).

How to avoid noise problems

The EMC 1UP contains delicate circuits that are sensitive to magnetic strayfields. The unit should not be place near mains transformers, TVs etc. Care should also be taken regarding placement of the interconnect cables. Do not run interconnect cables in parallel with mains cords and loudspeaker cables. Keep interconnect cables as short as possible.

Replacing remote control batteries

Replace used batteries by gently inserting your fingernail or small screwdriver in the groove on the left side of the battery compartment cover. Lift the cover off, and insert a fresh set of batteries. Be careful to follow the + and - polarity indications at the bottom of the battery compartment. Battery: 2 x LR03 / AAA: 1.5Volts.

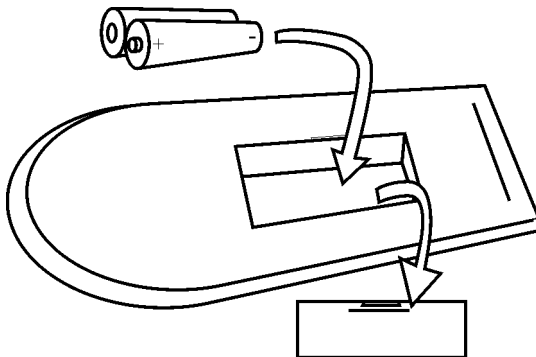

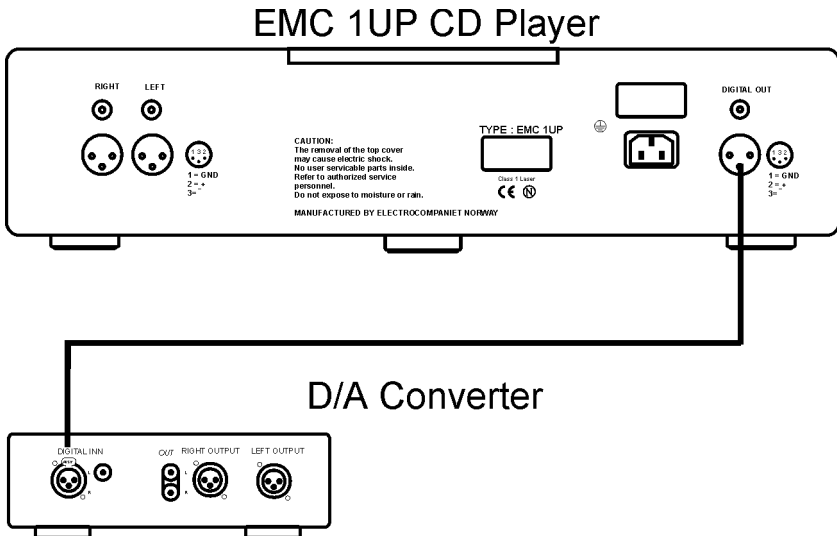
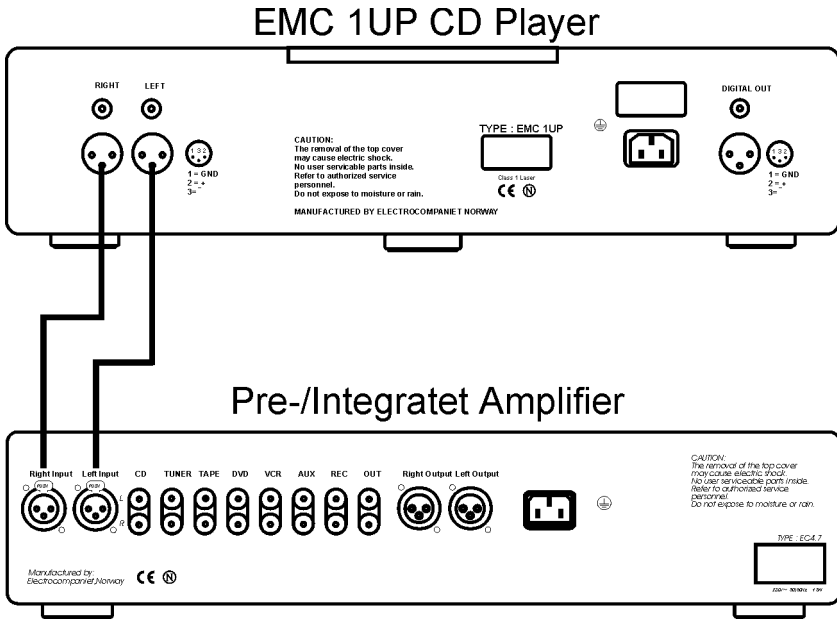

EMC 1UP CD Player

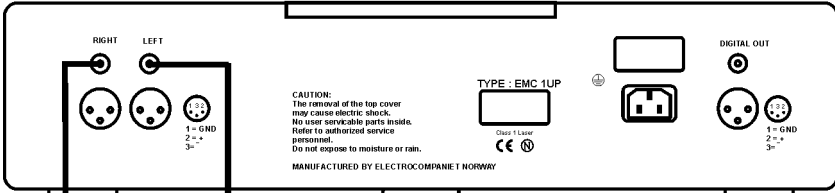

Pre-/Integretet Amplifier

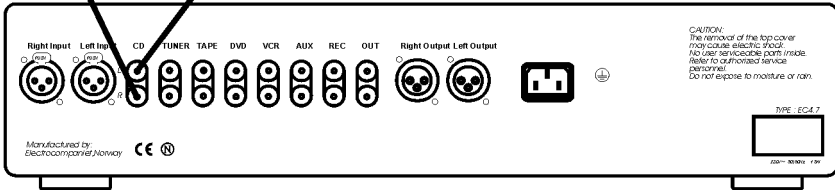

EMC 1UP CD Player

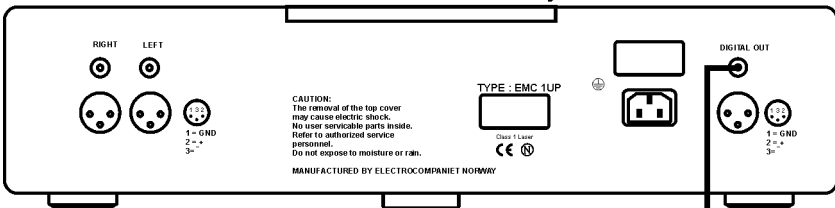

D/A Converter

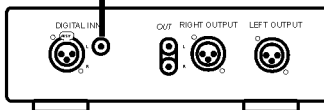

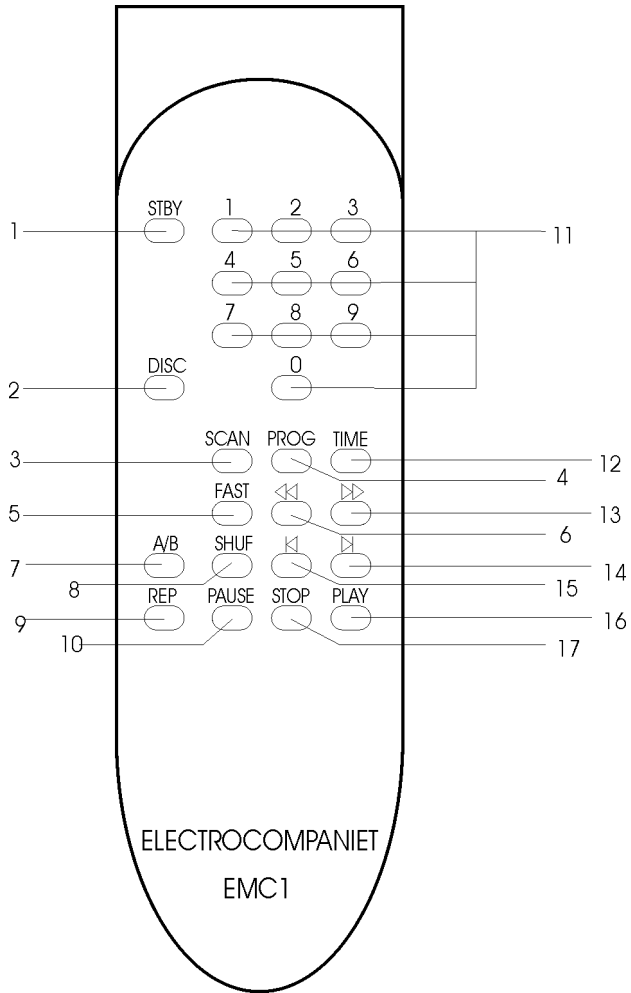

Remote control

1. **STANDBY**
2. **DISC** – No function.
3. **SCAN** – Play 10 seconds of each track.
4. **PROG**
 - a. Set the CD player in **STOP MODE**.
 - b. Select tracks with the numeric buttons (9), or step to the number using buttons no. **14** or **15**.
 - c. Press the **PROG (4)** button – the track is programmed.Repeat **b** and **c** until all the tracks you wish to program is done.

After each track is programmed, the total playtime will be shown in the display. If a track with number higher than 13 is programmed, the total playtime will not be shown.

You can browse through the tracks with the buttons **14** and **15**. On the tracks that already are programmed, you will see a “P” shown in the display. If you wish to remove a track from your program, choose the track number and press **PROG (4)**.To monitor what is being programmed. Go back to **STOP MODE**. Press **PROG (4)** – The display will now show the programmed tracks in the new order.The tracks are now stored in the order you programmed them and not in the original numeric order.If you press **STOP (17)** two times your program sequence will be erased.
5. **FAST** – press this button before you use the search buttons (**6** or **13**). The search will go faster.
6. **SEARCH BACKWARDS**
7. **A/B** – Repeat a segment of the disc/track. Press the button once to mark the start of the portion to be repeated. Press it again at the end of the desired sequence. The selected area will play continuously until the **STOP (17)** button is pressed.
8. **SHUF** - The tracks will be played in a random order.
9. **REP** – Press this button once and all the tracks on the disc will be repeated. The display will show “**REPEAT**”. Press the button again, and it will only repeat the current track. The display will show “**REPEAT 1**”
10. **PAUSE** – Pause on/off.
11. **NUMERIC CONTROLS** – Press these buttons to select a specific track on the disc. For tracks 10 and above, the second digit of the number must be pressed within one second.
12. **TIME** – Press once - shows total played time.
Press once more - shows total remaining time of disc.
Press once more - back to normal. (shows played time of single track)
13. **SEARCH FORWARD**
14. **NEXT TRACK**
15. **PREVIOUS TRACK**
16. **PLAY**
17. **STOP**

Front Panel Controls

The power on/off button is localised in the center of the front panel.

Generally, we recommend that you use the Standby button located on the remote control.

The display will go dark. The e- sign on top of the unit will still be lit, indicating Standby mode.

When not using the EMC 1UP for a long period, turn the main switch off and disconnect the unit from the mains outlet.

The four buttons on the right front panel have the following functions:

Top button = start/play

Right button = next

Left button = previous

Lower button = stop

How to power up your system

You should always power up your system the following way: Signal sources (CD player, tuner etc.) first. Allow a 30 seconds warm-up before you turn on the amplifier(s). When switching off your system: Start with the amplifier(s), then the signal sources.

Loading a Disc

1. Load the disc by gently pushing the drawer marked: ELECTROCOMPANIET towards the rear of the unit. «Open» is shown on the display.
2. Place the disc on the spindle. **Then place the CD-clamp on the spindle.** The clamp now securely fastens the disc.
3. Pull the cover all the way home. The CD player must first read and load vital information from the disc. This process, indicated by a flashing display, takes approximately three seconds. Tracks and total time are displayed.
4. Press start/play and the first track starts to play.
5. When changing a disc, press the stop button on the front panel or on the remote control before opening the drawer.
6. If the drawer is opened during playback, it will take the disc a few seconds to spin down.
7. Do not touch the disc until it has come to a complete standstill.

Warning:

The laser pick-up is located behind the spindle.

NEVER look directly into the laserbeam!!!

Under normal circumstances the laser needs no cleaning.

Do not use any kind of “cleaning CDs”!

Technical Specifications EMC 1UP

The following technical data were measured on randomized test objects and are typical data. All measurements are made at 120V / 240V // 50Hz / 60 Hz.

Analog stage

Measurements	Parameters	Single ended	Balanced
Output level	(RMS)	1.6 V	3.2 V
Gain		1.6 X (4 dB)	3.2 X (10 dB)
Maximum output	(RMS)	> 7 V	>14V
THD	(1 V out, 1 kHz)	< 0.002 %	
Channel separation	(1 V out, 1 kHz)	> 90 dB	
Equivalent input noise		4 uV	

Digital stage

Dynamic range		100 dB
Signal to noise		100 dB
THD		-100 dB
Frequency response	(20 - 20 kHz)	0 dB
Output		S/PDIF

Power consumption 23 W

The EMC 1UP has DC coupled analog output
Dimensions

Width	483 mm	-	19 inch
Depth	450 mm	-	17.7 inch
Height	120 mm	-	4.7 inch
Weight	20 kg	-	44 lbs

Specifications subject to change without notice.

If Service is needed

Your dealer will have all relevant information regarding the service centre in your area, and will ensure that your unit is serviced with minimum delay. It is our general policy to have your unit returned to you within five working days. This is an average time, and can vary locally, depending on the workload at that particular service station. If, for some reason, there are no service facilities available in your country, please ship the unit to the following address:

Electrocompaniet as,
Breivikveien 7,
N-4210 Tau,
Norway

E-mail: service@electrocompaniet.no

Web: www.electrocompaniet.no

The end user is responsible for all shipping charges, insurance, re-importation and duty charges. When shipping a product to the factory for service, always include the following:

1. A sales slip or other proof of purchase if repair is claimed under warranty.
2. A proforma invoice with value of goods, stating that the amplifier is returned to Norway for repair.
3. An accompanying letter describing faults, symptoms, or problems with the unit.
4. Always ship the unit in its original carton and packaging material to prevent damage in transit.

Electrocompaniet will not cover damages incurred in transit. If you require further information concerning the operation of the unit, or if you have any questions related to service, please do not hesitate to contact your dealer or your national distributor.

PLEASE REMEMBER TO FASTEN THE TRANSPORT SCREWS!



Made in Norway

WWW.ELECTROCOMPANIET.NO