



ELECTROCOMPANIET

# OWNERS MANUAL

## **EC-3 MC ANNIVERSARY DUAL MONO BALANCED PREAMPLIFIER**

WARNING: To reduce risk of fire or electric shock,  
do not expose this appliance to rain or moisture.  
Do not remove cover. No user serviceable parts inside.  
Refer to qualified service personell.

## **Thank you for selecting Electrocompaniet**

We sincerely thank you for selecting an amplifier from Electrocompaniet. We hope you will enjoy years of listening pleasure and true high end musical performance with your audio system. Kindly read this owners manual in order to familiarise you with the set before operation.

### **The Electrocompaniet Story**

Electrocompaniet was founded in 1973 in Oslo, Norway, to manufacture an amplifier designed by Per Abrahamsen. The design were based upon a new approach to transistor amplifier design developed by Dr. Matti Ojala and Jan Lohstro.

It had long been recognized that transistor amplifiers had a characteristic sound that many audiophiles and music lovers found unnatural.

Dr. Ojala and Mr. Lohstro analyzed transistor amplifiers to determine what actually created the "transistor sound" in general transistorized designs. The results of their innovative design work were incorporated into the first Electrocompaniet design, the legendary 25 watt amplifier.

This product were the first commercial transistor amplifier to use this new design approach, and the amplifier was immediately recognized as dramatically more musical sounding than any other transistor amplifier. The same design philosophy, which has been constantly updated through additional research and experience, is the basis for all the current Electrocompaniet Ampliwire and Preampliwire Dual Mono Balanced designs.

Electrocompaniet have always given extensive listening test of all its designs the highest priority. Every product designed by our engineers must meet the varied and exacting standards of the listening panel, carefully selected to represent a cross section of musical taste and experience. Electrocompaniet designs go back and forth between the design laboratory and the listening panel until both engineers and listeners are completely satisfied, and ensured the that the design has met its technical and sonical objectives.

All Electrocompaniet products are handmade by highly skilled technicians, and extensively tested for maximum performance and reliability.

Final adjustments are made only after an extended period of operation to insure the best possible performance under conditions similar to actual use.

Electrocompaniet Ampliwire and Preampliwire are sold in more than 25 countries , providing the ultimate listening pleasure to dedicated music lovers worldwide.

### **The design features of Preampliwire EC-3 MC Anniversary**

After the Electrocompaniet 25 watt amplifier had established a new standard for transistor amplifiers, research was undertaken to find ways to make the amplifier even better, and to extend its highly musical sound quality to more powerful amplifier designs. The engineers of Electrocompaniet were not satisfied by only reducing the commonly recognized types of distortion to low levels. They recognized that distortion appears in many forms, and that distortion was still audible in listening tests even when conventional categories of distortion were at vanishing low levels.

Traditionally, designers increased feedback to make a larger portion of the output signal control the amplifiers response. Our listening tests showed us that simply applying more feedback was not the answer. In fact, as one kind of distortion went down, other parameters would be adversely affected, leading to an overall degradation of sound quality. We knew that the other conventional design approach of eliminating feedback completely was not the answer either, because this would cause high distortion levels, and as a result "wooly" sound.

The answer to the dilemma was found in a novel approach to feedback theory. We developed a feedback concept that allowed local feedback to be applied around individual stages of the amplifier circuit. This approach allowed us to avoid the sonic disadvantages of overall feedback from output to input. The concept was further developed to reduce phase- and interphase distortion between stages of the amplifier as well. We were able to concentrate the loop feedback on the stages of the amplifier where it resulted in audible improvement.

Stability margins were also expanded because feedback no longer affected the frequency response. The use of this concept of individual gain blocks - complex in design but simple in function - allowed us to reduce distortion to minute values in all the products.

## **Unpacking the preamplifier:**

Immediately upon receipt of the preamplifier, inspect the carton for possible damage during shipment. If the carton is visibly damaged, a claim must be filed with the carrier as soon as possible.

Unpack the unit carefully, and please do remember to save all packaging materials for future shipment. The carton and packaging have been designed to offer the safest possible protection when transporting your amplifier, for the prevention of damage to the unit.

## **The content of the carton is as follows:**

- 1 pc Electrocompaniet Preamplifier EC-3 MC Anniversary
- 1 pcs Electrocompaniet EC-K3 AC powercord
- 1 pcs Owners Manual

## **Connecting EC-3 MC Anniversary**

### **Connecting to mains**

Check that the mains voltage printed on the rear panel of the preamplifier corresponds with the line voltage in the territory where you intend to connect your preamplifier.

### **The rear panel**

The rear panel of the Preamplifier EC 3MC contains all input- and output connectors. The printed rear panel clearly indicates the function of each connector. Please refer to drawing on page 9.

### **Connecting to the power amplifier**

For single-ended (normal) operation, the + terminal on right and left output are used for connection to the amplifier.

EC-3 MC is a fully balanced preamplifier, and by using all four RCA output terminals(+ and -, left and

right) your amplifier can be connected fully balanced, supposed the power amplifier is a balanced design. If your power amplifier is equipped with XLR connectors, use the XLR outputs of EC-3 MC.

### **Connecting a balanced CD player**

When using XLR connectors between the balanced output on CD player and the balanced XLR CD input on the EC-3 MC, always remove the shorting plugs from left and right - (negative) RCA CD inputs.

### **How to avoid noise problems**

The EC-3 preamplifier contains circuitry that might be sensitive to magnetic fields. The set should be placed well away from transformers, etc. Care should also be taken in routing all signal cables. They should not run parallel to speaker cables or AC cables (mains). Keep cables as short as possible. For minimum hum, the preamplifier should be placed on the right side of the power amplifier (because of the location of the MC circuitry). If placed above a power amplifier, leave at least 4" (10 cm) of space between the top of the amplifier and bottom of the preamplifier.

### **How to avoid damages**

A good operating practice is to turn off all equipment before any connections or disconnections are made. Do not under any circumstances connect or disconnect equipment when power is turned on. If you insist on connecting or disconnecting while power is turned on, you should be aware that the design of the RCA plug generates a large transient when inserting the plug. This could damage both the speakers and the amplifier.

### **Switches and controls**

The power on/off switch is located in center of the faceplate. After a delay of appx. 5 seconds, the LEDs will lit up. This delay allows the preamplifier to stabilize, and avoids on/off noise to reach your power amplifier.

This unit is equipped with separate record and listen switches. It is possible to listen (for instance) to a CD while taping another source - for instance a turntable or a tuner. The two rotary switches are located on the left half of the faceplate - a red LED in the record switch and a green LED in the listen switch.

The right half of the faceplate contains the volume- and balance controls, marked with a green and red LED, respectively.

## **Operating instructions:**

### **How to turn on your system**

You should always turn on your equipment in this order: Signal source devices (CD, tuner, etc) then the preamplifier, and finally, the power amplifier.

The EC-3 is delivered with 4 shorting plugs on the inputs. Remove the shorting plugs from the inputs you intend to use, but leave the plugs in position on all unused inputs. This will prevent unwanted noise and crosstalk from open inputs.

Never insert the shorting plug into an output, like Rec. Out or Main Out!

After turning on the preamplifier the first time, let it warm up for a few hours before you do any serious listening. We recommend that you - from a sonic point of view - leave the preamp "ON" all the time, except when being away for longer periods, or during heavy thunderstorms

## Matching EC-3 MC to different cartridges

The "correct" load for an MC cartridge must be determined by careful listening. Proceed acc. to steps listed below:

- Find the DC impedance of the cartridge. This is normally written in the manual of the cartridge as source- or internal impedance. This value could also be measured with an Ohm-meter across on channel of the cartridge.
- Set the load by changing positions of the dip-switches referd to as SW 0 on the MC board to match the DC impedance as close as possible. A higher load resistance value selected than in the cartridge will give smother high frequency, but above a certain step, the bass will be less defined. A lower load resistance will give tighter bass, but high frequency will tend to be harsh.
- The correct setting for your system can only be detrmind by listening, and the set load-value will greatly influence the overall sound.
- Changing the load in the preamplifier can be made with the set "on" and in operation. The switches can be reached through the ventilation slots in the topcover, by a toothpick etc. Always turn the volumecontrol down to minimum before switching or select another (unused) input while load is changed - and return to phono input afterwards.
- Switchable cartridge load is 6 ohm to 100 ohm.
- SW 1 determines the gain for the MC cartridge. Start with appx. 10 times the DC impedance of the cartridge. For more gain, increase the value on SW 1.

The drawing below will help you identify the switches SW 0 and SW 1. The charts/lists on the two next pages guides you how to select a specific impedance and gain, as well as listing the suggested setting for a number of frequently used MC cartridges.

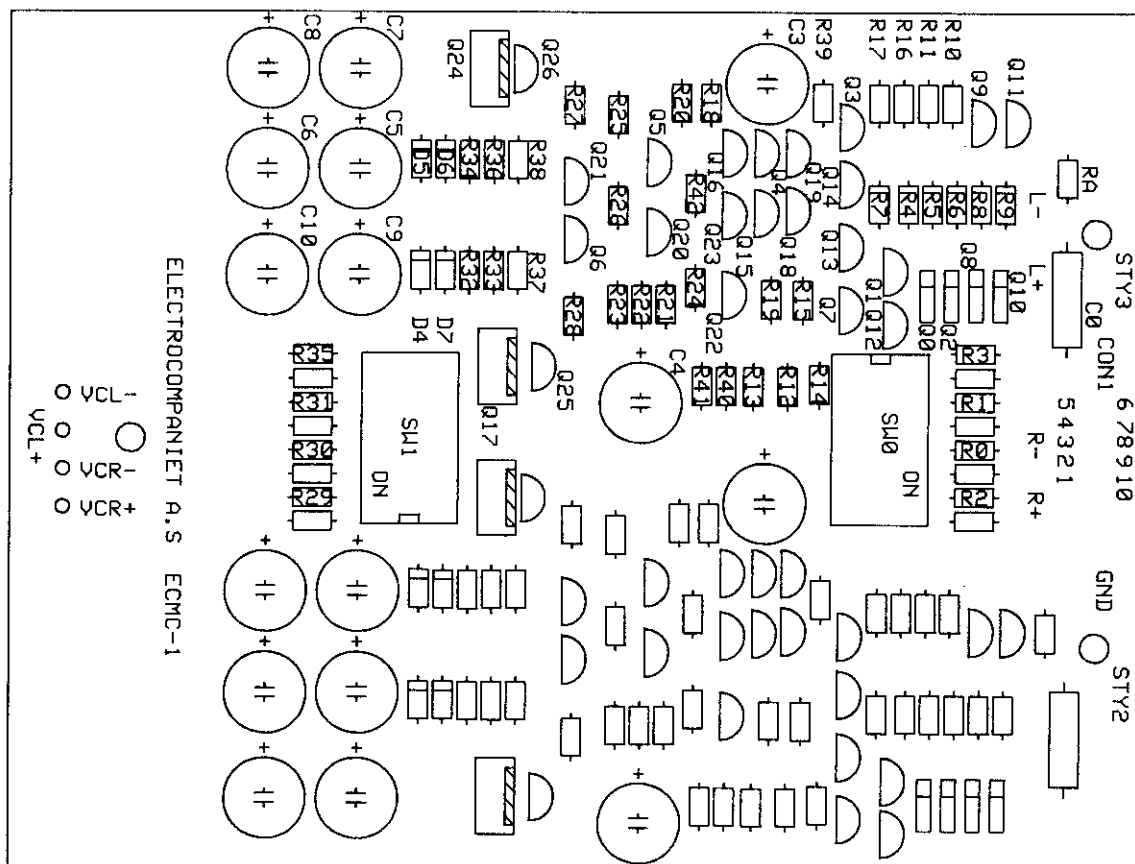

REAR SIDE OF PREAMPLIFIER

## Moving Coil amplifier settings

### For location of switches, see page 5

The switches SW 0 and SW 1 are located on the MC board on the right side of the preamplifier when viewed from the front. The switches can be seen and operated through the ventilation slots in the topcover of the preamplifier.

The standard setting from the factory is SW 0: **10,0 Ohm**, SW 1: **270,0 Ohm**

#### Settings of the SW 0

#### Settings of the SW 1

LOAD	1+2	3+4	5+6	7+8	GAIN SET	1+2	3+4	5+6	7+8
$\infty$ $\Omega$	off	off	off	off	0	off	off	off	off
6.1 $\Omega$	on	on	on	on	111.7 $\Omega$	on	on	on	on
6.5 $\Omega$	off	on	on	on	131.3 $\Omega$	off	on	on	on
7.1 $\Omega$	on	off	on	on	139.6 $\Omega$	on	off	on	on
7.5 $\Omega$	on	on	off	on	146.6 $\Omega$	on	on	off	on
7.7 $\Omega$	off	off	on	on	171.5 $\Omega$	off	off	on	on
8.1 $\Omega$	off	on	off	on	182.2 $\Omega$	off	on	off	on
9.1 $\Omega$	on	off	off	on	190.6 $\Omega$	on	on	on	off
10.0 $\Omega$	off	off	off	on	198.5 $\Omega$	on	off	off	on
15.7 $\Omega$	on	on	on	off	255.5 $\Omega$	off	on	on	off
18.7 $\Omega$	off	on	on	off	288.9 $\Omega$	on	off	on	off
24.8 $\Omega$	on	off	on	off	320.6 $\Omega$	on	on	off	off
30.0 $\Omega$	on	on	off	off	270.0 $\Omega$	off	off	off	on
33.0 $\Omega$	off	off	on	off	470.0 $\Omega$	off	off	on	off
43.0 $\Omega$	off	on	off	off	560.0 $\Omega$	off	on	off	off
100.0 $\Omega$	on	off	off	off	750.0 $\Omega$	on	off	off	off

## Suggested settings

### Reference chart

Below is a list of frequently used Moving Coil cartridges. The load impedance is recommended from the cartridge manufacturer, and our values are our suggested settings. For optimum performance, we recommend that you try out different values in your specific audio system.

MC-cartridge :	SW0				SW1			
	1+2	3+4	5+6	7+8	1+2	3+4	5+6	7+8
Accuphase AC-3	off	off	on	off	off	off	off	on
Denon DL-103D	on	off	off	off	on	off	off	off
Highphonic MC-A2e	off	on	off	off	off	on	off	off
Koetsu "family"	off	off	off	on	off	off	off	on
Ortofon MC-10 Super	off	off	off	on	off	off	off	on
Ortofon MC-20 Super	off	off	off	on	off	off	off	on
Ortofon MC-30 Super	off	off	off	on	off	off	off	on
Ortofon MC-2000	off	off	off	on	off	on	off	off
Ortofon MC-3000	off	off	off	on	off	on	off	off
Sumiko Talisman A	off	on	off	off	off	on	off	off
Sumiko Talisman B	off	on	off	off	off	on	off	off
Sumiko Talisman S	off	on	off	off	off	on	off	off
van den Hul MC-10	off	off	on	off	off	on	off	off
Factory setting	off	off	off	on	off	off	off	on

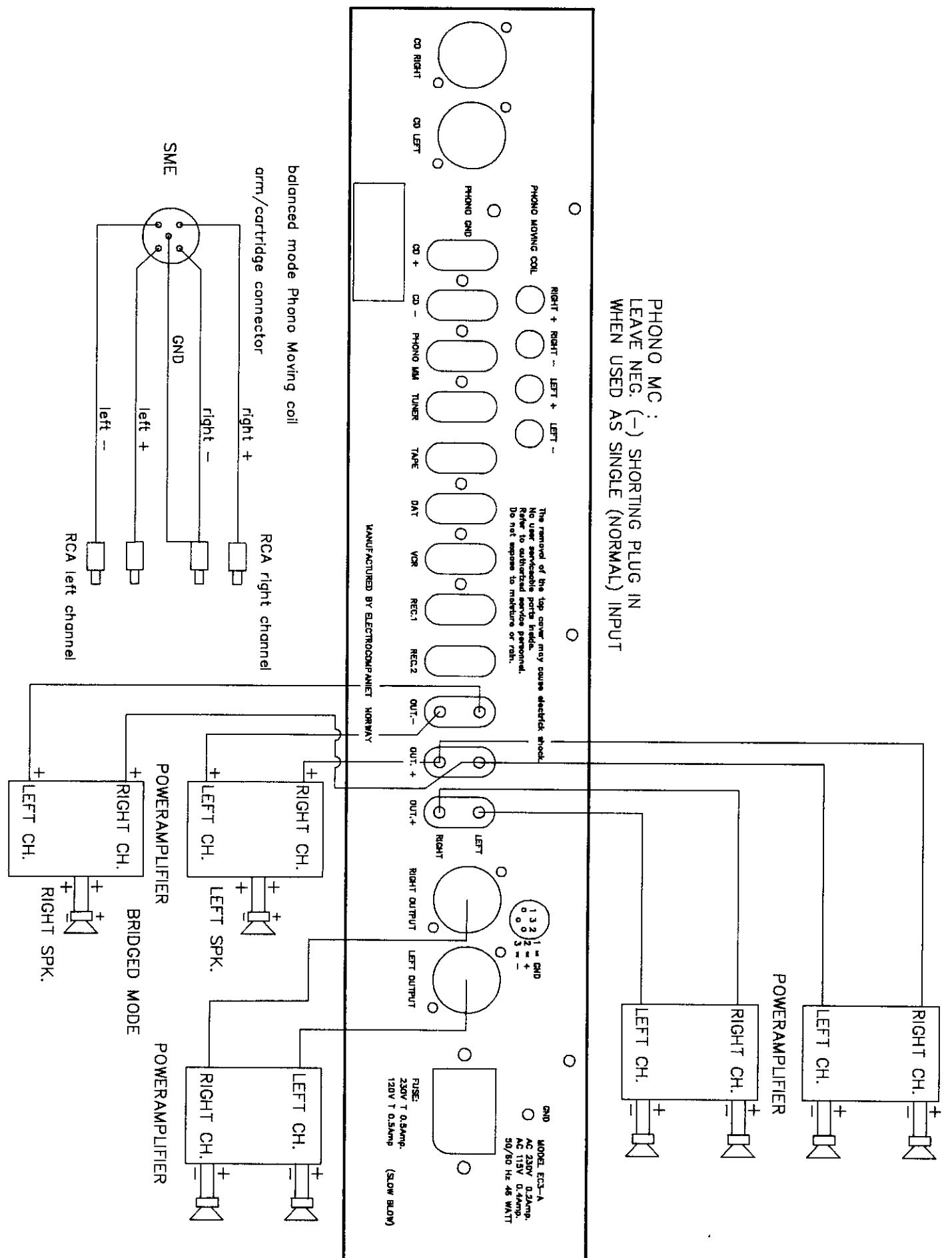



## Technical Specifications:

The following technical data were measured on randomized test objects and were typical data. All measurements are made with the following equipment:

Distortion analyzer:	Tektronix AA501
Oscilloscope:	Tektronix 468
Oscillator:	Tektronix SG505
Frequency counter:	Rascal 9838
Phase meter:	Hewlett Packard 3575A

### Phono stage

Phono input to record output:

Gain 1 KHz Moving Coil (source impedance = 10 ohm)	52 dB (398x)
Gain 1 KHz Moving Magnet	32,6 dB (43x)
Input Impedance Moving Magnet	47 Kohm//22pF
THD 1 KHz (3V output)	less than 0,004%
Overload 1 KHz Moving Coil (THD = 0,2%)	more than 25 mV
Overload 1 KHz Moving Magnet (THD = 0,2%)	more than 290 mV
Channel separation (1V output at 1 KHz)	more than 90 dB
Noise A weighted (ref. 0,5 mV) Moving Coil	-85 dB
Noise A weighted (ref. 5 mV) Moving Magnet	-85 dB
Equivalent input noise (400 Hz - 300 KHz)	0,2 uV
RIAA Accuracy (20 Hz - 200 KHz)	+/- 0,1 dB

Line input to record output:

Input impedance	47 Kohm//22pF
Gain	1:1
THD 1 KHz (5V output)	less than 0,002%
Overload 1 KHz (THD = 0,2%)	more than 10V (130 dB)
Channel separation (1V output at 1 KHz)	more than 90 dB
Equivalent input noise	3 uV

### Line stage

Single ended operation:

Gain (6,5 x)	16 dB
THD (1 KHz 1V input, 1V output)	0,003%
Max output (THD = 0,2%)	more than 14V RMS
Channel separation (1V output at 1 KHz)	more than 90 dB
Equivalent input noise	1,5 uV
Output impedance	100 ohm

Balanced operation:

Gain (13x)	22 dB
THD (1 KHz input, 2V output)	0,003%
Max output (THD = 0,2%)	more than 28V RMS
Channel separation (1V output at 1 KHz)	more than 90 dB
Equivalent input noise	3,0 uV

Output impedance		100 ohm
Dimensions	Width	483 mm (19 inches)
	Depth	227 mm (11 inches)
	Height	87 mm (3,5 inches)
Weight		18 kg (40 lbs)

The manufacturer reserves the right to alter these specifications without further notice.

**Personal notes:** (always note impedance and gain setting for future reference)