

BRYSTON

BP-17³ Cubed Series Preamplifier

Owner's Manual

Important Safety Instructions



The lightning flash with arrowhead symbol within an equilateral triangle, is intended to alert the user to the presence of uninsulated “dangerous voltage” within the product’s enclosure that may be of sufficient magnitude to constitute a risk of electric shock to persons.



The exclamation point within an equilateral triangle is intended to alert the user to the presence of important operating and maintenance (servicing) instructions in the literature accompanying the product.

1. Read these instructions.
2. Keep these instructions.
3. Heed all warnings.
4. Follow all instructions.
5. Do not use this apparatus near water.
6. Clean only with dry cloth.
7. Do not block any ventilation openings. Install in accordance with the manufacturer’s instructions.
8. Do not install near any heat sources such as radiators, heat registers, stoves, or other apparatus (including amplifiers) that produce heat.
9. Do not defeat the safety purpose of the polarized or grounding-type plug. A polarized plug has two blades with one wider than the other. A grounding type plug has two blades and a third grounding prong. The wide blade or the third prong are provided for your safety. If the provided plug does not fit into your outlet, consult an electrician for replacement of the obsolete outlet.
10. Protect the power cord from being walked on or pinched particularly at plugs, convenience receptacles, and the point where they exit from the apparatus.
11. Only use attachments/accessories specified by the manufacturer.
12. Use only with the cart, stand, tripod, bracket, or table specified by the manufacturer, or sold with the apparatus. When a cart is used use caution when moving the cart/apparatus combination to avoid injury from tip-over.
13. Unplug this apparatus during lightning storms or when unused for long periods of time.
14. Refer all servicing to qualified service personnel. Servicing is required when the apparatus has been damaged in any way, such as power-supply cord or plug is damaged, liquid has been spilled or objects have fallen into the apparatus, the apparatus has been exposed to rain or moisture, does not operate normally, or has been dropped. **NO USER SERVICEABLE PARTS INSIDE**



WARNING: TO REDUCE THE RISK OF FIRE OR ELECTRIC SHOCK, DO NOT EXPOSE THIS APPARATUS TO RAIN OR MOISTURE. DO NOT EXPOSE THIS EQUIPMENT TO DRIPPING OR SPLASHING AND ENSURE THAT NO OBJECTS FILLED WITH LIQUIDS, SUCH AS VASES, ARE PLACED ON THE EQUIPMENT. TO COMPLETELY DISCONNECT THIS EQUIPMENT FROM THE AC MAINS, DISCONNECT THE POWER SUPPLY CORD PLUG FROM THE AC RECEPTACLE. THE MAINS PLUG OF THE POWER SUPPLY CORD SHALL REMAIN READILY OPERABLE.

BRYSTON LIMITED WARRANTY

Bryston analog audio products are warranted to be free from manufacturing defects for twenty (20) years from the original date of manufacture. The warranty includes parts and labour. Bryston digital products and cables are warranted for five years from the original date of manufacture. The warranty includes parts and labour.

Bryston products having motorized moving parts, excluding motorized volume controls, are warranted for three years from the original date of manufacture. The warranty includes parts and labour.

Bryston will remedy the problem by repair or replacement, as we deem necessary, to restore the product to full performance. Bryston will pay return shipping only for the full length of the specific product’s warranty.

In the event of a defect or malfunction, contact Bryston’s repair centers for return authorization. Products must be returned using original packaging material only. Packing material may be purchased from Bryston if necessary. This warranty is considered void if the defect, malfunction or failure of the product or any component part was caused by damage (not resulting from a defect or malfunction) or abuse while in the possession of the customer. Tampering by persons other than factory authorized service personnel or failure to fully comply with Bryston operating instructions voids the warranty. This warranty gives you specific legal rights and you may also have other rights which may vary from province to province and country to country. As of 2006-02-22 Bryston will only warranty Bryston products purchased through authorized Bryston dealers. Bryston products with a date code of 0608 or higher (date code format is “yyww”, where “yy” is the two least significant digits of the year and “ww” is the week of the year) must be accompanied by a copy of the bill-of-sale from a Bryston authorized dealer to qualify for warranty service. The warranty is transferable from the original owner to a subsequent owner as long as a copy of the bill-of-sale from the original authorized Bryston dealer accompanies the re-sale. The copy of the bill of sale to any subsequent owner need ONLY include the Name of the Bryston Authorized Dealer and the Model and Serial number of the Bryston product. The warranty will only be honored in the country of the original purchase unless otherwise pre-authorized by Bryston.

BRYSTON SERVICE in CANADA:

Postal address: P.O. BOX 2170, Stn. Main
PETERBOROUGH, ONTARIO
CANADA K9J 7Y4

Courier address: 677 NEAL DRIVE
PETERBOROUGH, ONTARIO
CANADA K9J 6X7

PHONE: 705-742-5325
FAX: 705-742-0882
E-mail: cdnser@bryston.com

BRYSTON SERVICE in the USA:

79 COVENTRY ST., Suite 5
NEWPORT, VERMONT
U.S.A. 05855-2100

PHONE: 802-334-1201
FAX: 802-334-6658
E-mail: usaser@bryston.com

BRYSTON SERVICE outside Canada and the USA:

contact your local distributor or

CHECK OUR WEB SITE: www.bryston.com
E-MAIL BRYSTON DIRECTLY: cdnser@bryston.com
FAX BRYSTON DIRECTLY: 01-705-742-0882
PHONE BRYSTON DIRECTLY: 01-705-742-5325

Table of Contents

Important Safety Instructions	2
General.....	4
Welcome	4
Description	4
Features	4
Shipping Box and Packing Material.....	4
Installation.....	4
Ventilation	4
Connecting to A/C Power	4
Connecting to Audio Components	4
Connecting Source Components.....	4
Connecting Amplification	4
Optional Modules.....	5
Moving Magnet Phono	5
Digital to Analog Converter (DAC)	5
Remote Control	5
Serial Protocol.....	5
Trigger Control	6
Specifications and Dimensions	7
Front Panel	8
Rear Panel.....	9

General

Welcome

Thank you for your purchase of a Bryston BP-17³ Cubed Series Stereo Preamplifier! This new preamplifier is the first line-level component to feature our patented Salomie buffer which dramatically reduces distortion at the input stage thereby reducing distortion of the entire audio system. The BP-17³ is designed to operate with superb reliability and class leading sound quality for a generation or more. We welcome your feedback and hope you enjoy your new BP-17³ for many years to come.

Description

The BP-17³ is a top quality stereo analog preamplifier featuring a variety of balanced and unbalanced inputs and outputs for connecting your choice of source components and amplifiers.

Features

Bryston BP-17³ includes the following features:

- 4 RCA single-ended analog stereo input pairs and 2 XLR balanced stereo input pairs.
- Optional digital to analog converter
- Optional MM phono stage
- Fixed level output and record input permit use of equalizer or tape recorder in signal path.
- Remote control RS232 or IR including Bryston BR-2 remote control.
- Available in either 17 inch or 19 inch wide C-Series dress panel in silver-toned (clear anodized) or black anodized aluminum.

Shipping Box and Packing Material

Please keep the original shipping box and all packing material. This will ensure the BP-17³ is protected in future transport. In the unlikely event you have a problem and must return it for service, you must use the proper packing material. Ship the BP-17³ only in the original packing material as the unit is not insurable by carriers otherwise. Replacement packing materials consisting of a shipping carton with plastic foam inserts is available

from Bryston for a small fee.

Installation

Ventilation

The BP-17³ is a cool-running line level component. It generates far less heat than amplifiers and many other components. It can be safely placed inside furniture or an equipment rack. However, it should not be tightly enclosed. Some airflow is desired. Maintain a minimum of 0.5" to each side and 1.5" space above the unit to ensure proper airflow.

Connecting to A/C Power

Please check the Data Plate on the rear of the unit to verify power requirements agree with your location. Plug the IEC-320 C14 end of the power cord into the BP-17³, then plug the other end into an approved and grounded A/C receptacle.

Connecting to Audio Components

The BP-17³ is a very low distortion, high resolution stereo preamplifier that will perform at the highest level in virtually all two-channel stereo systems. Use high quality interconnect cables and make firm connections. Balanced connections are usually preferred for their ability to effectively reject common mode noise though you should still expect excellent results with unbalanced equipment.

Connecting Source Components

Analog source components can be connected to inputs with either balanced XLR interconnects or unbalanced RCA interconnects.

Connecting Amplification

The BP-17³ features a variety of output methods to ensure compatibility with a wide variety of amplifiers. Based on the type of inputs available on your amplifier, connect one of the variable outputs (Balanced Output 1, Balanced Output 2, or Preamp Output) to your amplifier.

BP-17³ Cubed Series Preamplifier

Optional Modules

The BP-17³ may be optionally equipped with a moving magnet phono input and/or a digital to analog converter. These may be fitted at the time of ordering or retrofit at a later time by a certified technician.

Moving Magnet Phono

The optional MM Phono input occupies INPUT 2, so input 2 can no longer be used for line level source components such as tuners, CD players, etc. This high quality phono stage is the same circuit found in our stand alone BP-2 MM.

Digital to Analog Converter (DAC)

The DAC is a high quality module that shares INPUT 1. That is, INPUT 1 can still operate as a standard analog stereo input pair, but it can also operate as two separate S/PDIF digital coaxial inputs. When the DAC module is installed, digital inputs 1 and 2 (TOSLINK optical connectors) are also connected and activated. In total, when the DAC is installed, 4 digital inputs are available for use. To select a DAC input, press the DIGITAL ► SELECT button on the front panel or the BR-2 remote control, then press the button that corresponds with the input you wish to hear. The DAC can receive PCM digital audio at 44.1kHz, 48kHz, 88.2kHz, or 96kHz sampling rates and 16 or 24 bit resolution. When a digital input is activated, the LED above 1 will illuminate green. The LED above the selected digital input will illuminate red when the input is selected and green when it is selected locked to a compatible digital audio source. Each input will remember whether analog or digital was last selected.

Remote Control

The BP-17³ can be controlled and monitored through RS232 and IR.

Serial Protocol

The BP-17³ can receive commands, send acknowledgment of commands received, and can be queried for certain statuses.

Using the DB9 female connector at the rear of the unit, the BP17 can receive commands via a straight-through cable at 9600 baud, 8 data bits, no parity and 1 stop bit (9600,8,N,1). Valid commands will return the ">" character indicating that the unit is ready to receive a new command. An invalid command will return the "!" character.

These serial data commands are as follows:

Category	Cmd.	Description
Power	000	Power Off
	029	Power On
	015	Toggle On/Off
Volume	007	Volume Up
	008	Volume Down
	009	Toggle Mute
	058	Mute On
	059	Mute Off
	950	Query current master level
	4xx	Discrete volume set where xx=00 to 80 (0dB to -80dB)
Source	001	Input 1
	002	Input 2 / Phono
	003	Input 3
	004	Input 4
	005	Balanced Input 1
	006	Balanced Input 2
	061	Toggle Record Monitor
	062	Record Monitor On
	063	Record Monitor Off
	081	Digital Input 1
	082	Digital Input 2
	083	Digital Input 3
	084	Digital Input 4
	245	Toggle Home Theater Bypass (unity gain) for current input
Balance	019	Balance Left
	020	Balance Right
	955	Query balance left/right levels
Trigger	247	Set Trigger 2 for current input
	248	Clear Trigger 2 for current input
System	255	Default system settings
	990	returns model, serial, and rev numbers and date code

IR Control

You may control the BP-17³ with a traditional infrared remote control such as Bryston's BR2.

To use a Bryston BR2 with the BP-17³, press the PREAMP button. Volume and Mute remain active even when the remote is in D/A or CD mode.

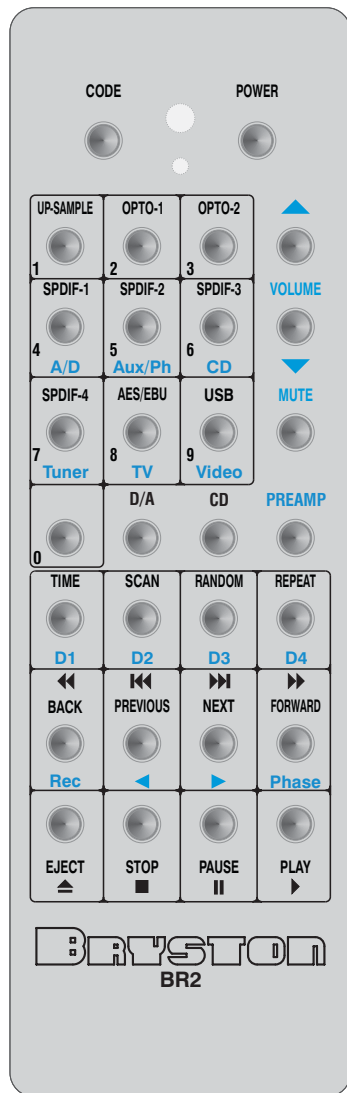

To configure the BR-2 for control over the BP-17³, execute the following steps:

1. Press and hold the CODE button on the BR2 remote until the red LED begins to flash (usually takes about 5 seconds).
2. As soon as the LED remains steadily RED, release

the CODE button and enter the the 3 digit code 712 before the LED goes out. The LED will flash twice after a valid code has been successfully entered.

Inputs 1-4, Balanced Input 1 and Balanced Input 2 can be selected by pressing the buttons that correspond with 1-6 where 5 and 6 select Balanced Input 1 and Balanced Input 2 respectively. Digital inputs D1-D4, Record Monitor, Balance L/R are marked in blue.

Special codes such as those used for bypass or trigger assignment can be sent by pressing the CODE button once, then entering the 3 digit code.

HEX codes for use with universal remote controls are available from Bryston upon request.

Trigger Control

The BP-17³ can control the power state of other attached devices. Two DC trigger outputs are provided. Each is a tip/sleeve (mono mini plug) and is wired with the tip at V_{DC} and sleeve ground.

Trigger 1 will commonly be used to trigger the attached amplifier(s) on or into standby as it is not source dependent. When the BP-17³ is powered on, voltage is present at the tip of this connector and is removed when the unit is placed into standby.

Trigger 2 can be configured to activate based on a selected source. Voltage is present at the tip of this connector when a specific source is selected. For instance, if a BCD-3 CD player is connected to Balanced Input 1, you may wish to configure Trigger 2 to activate on when Balanced Input 1 is selected. To assign Trigger 2 to an input, select that input and issue the command 247 using the BR-2 or RS232. Issue command 248 to clear Trigger 2 from that input.

BP-17³ Cubed Series Preamplifier

Specifications and Dimensions

Frequency Response	20Hz - 20kHz: ± 0.05 dB
THD	1V rms Bal. In/Out: $<0.0025\%$
IMD	$\leq 0.0003\%$
Noise	<10 Hz- 20 kHz, relative to full output RCA IN/OUT: -102 dB XLR IN/OUT: -108 dB
Input Impedance	Unbalanced: 6.5 k Ω Balanced (non inverting): 4.5 k Ω Balanced (inverting): 4.5 k Ω
Gain	RCA IN / RCA rec out: 0 dB RCA IN / RCA preamp out: 12 dB MAX XLR IN / XLR fixed out: 6 dB XLR IN / XLR preamp out: 18 dB
Weight	5kg 11 lbs
Dimensions (See Diagram)	Inches: 17 or 19 W x 4.55 H x 13 D Cm: 43. or 48.3 W x 11.6 H x 33 D
Power Consumption at 120V/60Hz	Standby: 2W Idle: 32W Full Power: 32W

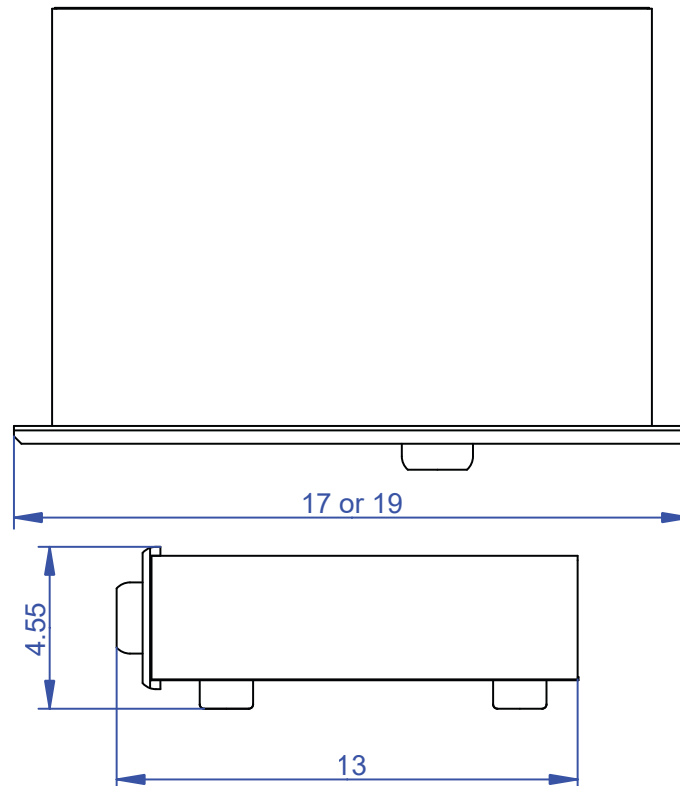

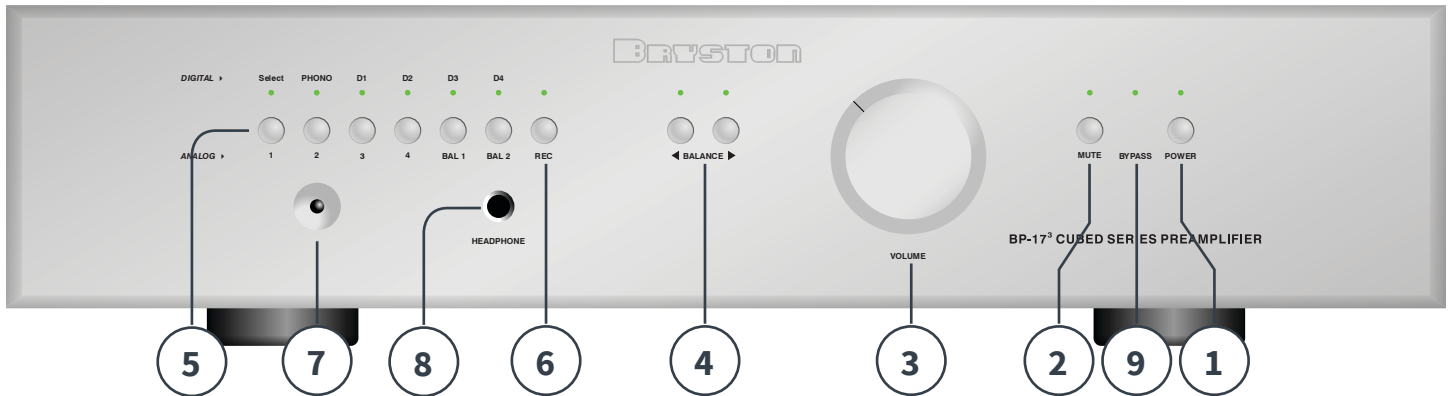

Front Panel

1. Power / Standby

Press this button to toggle the BP-17³ on or into standby mode.

Unlit	BP-17 ³ is not receiving power. Plug unit into AC mains power.
Red	Plugged into AC Mains but in standby mode.
Green or Blue	BP-17 ³ is on and operational.
Blinking Red	Receiving valid IR or RS232 data
Blinking Red/Green	Fault indicated. Contact customer service

2. Mute

Pressing this button or the Mute button on the BR-2 will disconnect the main outputs. When the unit is muted, the LED will illuminate red. Mute does not affect the headphone or record outputs.

3. Volume Control

Rotate this knob clockwise to increase the output volume or counterclockwise to decrease the volume.

4. Balance Control

Adjust the left / right balance of audio output by pressing the corresponding buttons on the front panel. Each button press will attenuate that channel by 1dB. When either channel is attenuated, the LED above the affected channel will illuminate green. Upon the 7th press of either channel's balance button, the channel

will fully mute and the LED above that channel will illuminate red. Balance does not affect the record output.

5. Input Selectors

The BP-17³ features 6 analog inputs plus one record input into which you can connect analog source components. When the BP-17³ is fitted with the optional DAC module, 5 analog inputs are available plus 4 digital inputs. When the BP-17³ is fitted with the optional MM Phono module, 5 line level analog inputs plus one MM phono input are available.

- BP-17³ Standard: Pressing any of the 7 input buttons selects the corresponding analog line level input for listening.
- BP-17³ Phono: Same functionality as the standard BP-17³ except that input 2 is reserved for input from a turntable and cannot be used with regular line level analog components.
- BP-17³ DA: Analog input one can also accept digital S/PDIF audio. Left becomes D3 and Right becomes D4. The two TOSLINK optical digital inputs (D1 and D2) are also populated. Pressing the Select / 1 button toggles between analog and digital input. To select a digital input, press the Select / 1 button. The LED above it will illuminate green. Then press the input button that corresponds with the digital input that you would like to listen to. To reactive analog mode in order to select an analog input for listening, press the Select / 1 button once again.

6. Record Input

Though this input can be used as a standard analog input, the previously selected input will still accept audio. This special input allows for monitoring of audio coming back in from a

BP-17³ Cubed Series Preamplifier

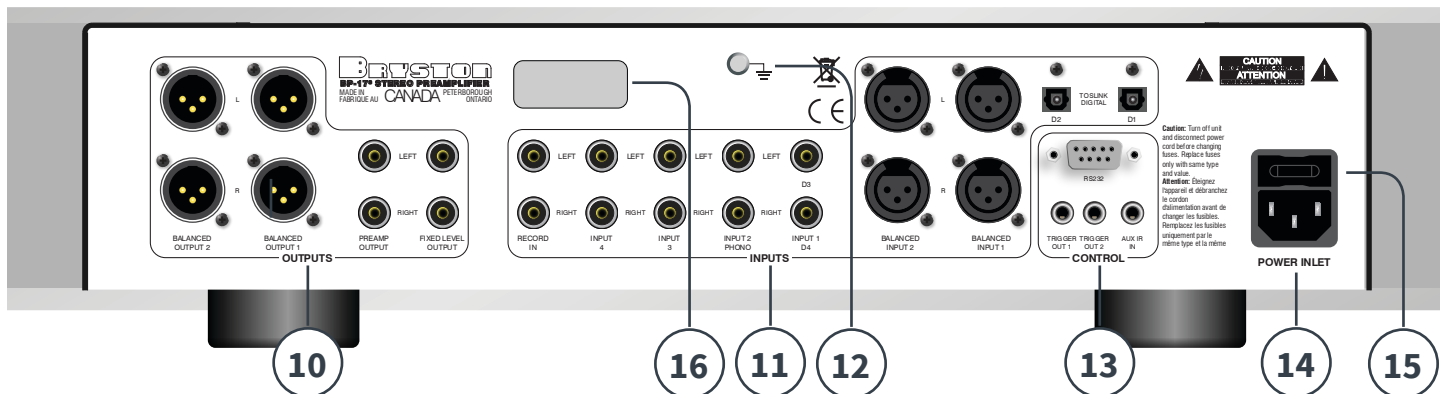

recorder that is currently receiving audio from the fixed level outputs on the back of the BP-17³.

7. IR Receiver

The BP-17³ can be controlled using Bryston's BR-2 or another remote control.

8. Headphone Output

Connect headphones to this output. The output is a 1/4" (6.35mm) TRS connector where the Tip=Left, Ring=Right, and Sleeve=Ground. Output impedance is 50Ω. Main outputs are muted when headphones are connected.

9. Bypass Indicator

One input can be configured as a unity gain home theater bypass input. When bypass mode is engaged for an input, this LED will illuminate green. To toggle bypass for the selected input, enter the code 245 using the BR-2 or RS232. Note that when bypass is engaged, balance and volume controls are defeated.

Rear Panel

10. Output Section

The BP-17³ is equipped with 4 stereo analog outputs.

- Balanced Output 1: Variable output. Pin 1=GND, Pin 2=Positive, Pin 3=Negative (configurable as fixed output at time of order or later by certified technician)
- Balanced Output 2: Variable output.
- Preamp Output: Variable output, single ended.
- Record Output: Fixed level output, single ended.

11. Input Section

Five stereo pairs of single-ended analog inputs and two stereo pairs of balanced analog inputs are available to receive audio from analog source components. When equipped with an optional digital to analog converter module, Input 1 can be divided into two separate S/PDIF inputs, and TOSLINK optical digital inputs D1 and D2 become available for use. When equipped with an optional MM phono option, Input 2 may be connected directly to a turntable and can no longer be used as a line-level input.

12. Chassis Ground

Connect this post to the ground wire from your turntable when the BP-17³ is equipped with the MM Phono module.

13. Control I/O

The BP-17³ features several control methods in addition to the IR receiver on the front panel. A full two-way RS232 suite is available. See "Remote Control" on p.5. Two DC triggers can modulate the power state of amplifiers, source components, or other equipment. An auxiliary IR input can be used with an external IR receiver "eye" terminated with a 3.5mm plug.

14. A/C Power Input:

An IEC-320 C14 power inlet provides for connection of an IEC-320 C13 equipped power cord. Before connecting the power cord to the amplifier, check that the voltage rating on the data plate or ratings label conforms with your locality.

(continued on next page)

15. Master Fuse Compartment:

The BP-17³ is protected by an AC Mains fuse specifically rated for the AC power in your region. The fuse must be installed and in tact for the amplifier to power on and operate. Only replace the fuse with one of identical value.



Do not attempt removal or replacement of the fuse when the amplifier is plugged into the wall!

16. Data Plate:

Unit specific information is printed here including model number, operating voltage, frequency, and serial number.

BP-17³-17-SIL-120
~120V 60Hz 35W
Serial No BP-17³-00000
Date: 1530 REV: 1234

BP-17³ Cubed Series Preamplifier

This page intentionally left blank

Bryston Limited | 677 Neal Drive | Peterborough, Ontario K9J 6X7
Canada | Phone: 705-742-5325 | www.bryston.com

300068-5

08-28-2017

Downloaded from www.linephaze.com

- Find specs, manuals and used listings across thousands of audio products.